

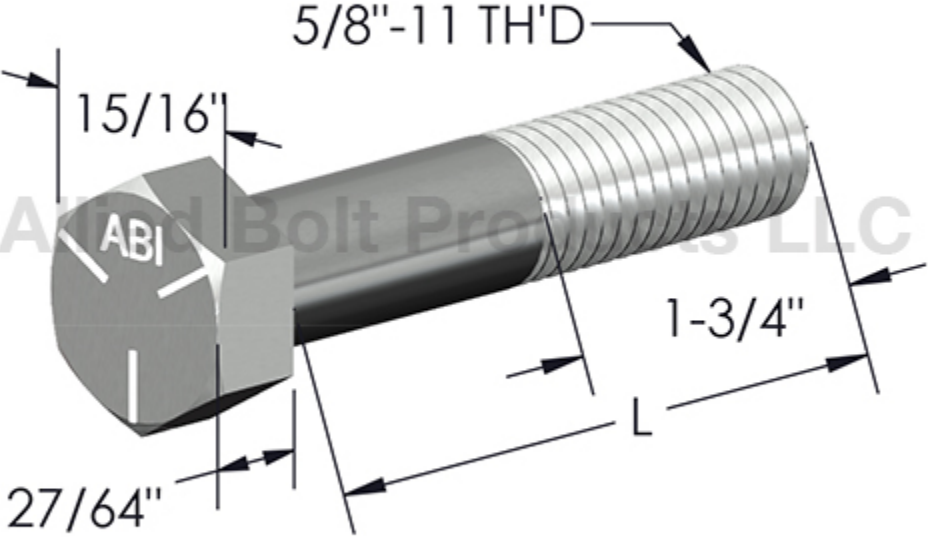

#50714

- Grade 5 bolts conform to ASTM A449 Type 1 and SAE J429 Grade 5.
- Grade 5 bolts are zinc plated to meet ASTM Specification F1941.
- Bolts conform to the dimensions of ASME B18.2.1.
- Minimum tensile strength: 27,100 lbf.
- Recommended torque value: 178.7 ft lb.
- Thread length: 1-1/2".

50714	5/8"-11 X 12" GRADE 5 HEX CAP SCREW ZINC PLATED	50	1	60
-------	--	----	---	----



April 01, 2026