



## #74510

- Designed for use in corrosive environments.
- Bolt and nut are thermal diffused galvanized using Greenkote's™ process to withstand 3,000 hours of Salt Spray per ASTM Specification B117.
- Thermally Diffused Galvanized per ASTM Specification A1059 and then treated with a silicate based top-coat.
- Bolts have assembled Regular Square Nuts.
- Bolts have Cone Points to ease assembly.
- Minimum tensile strength is 14,100lbf.

74510

5/8" X 10" OVAL EYEBOLT - TDG

35

1

50

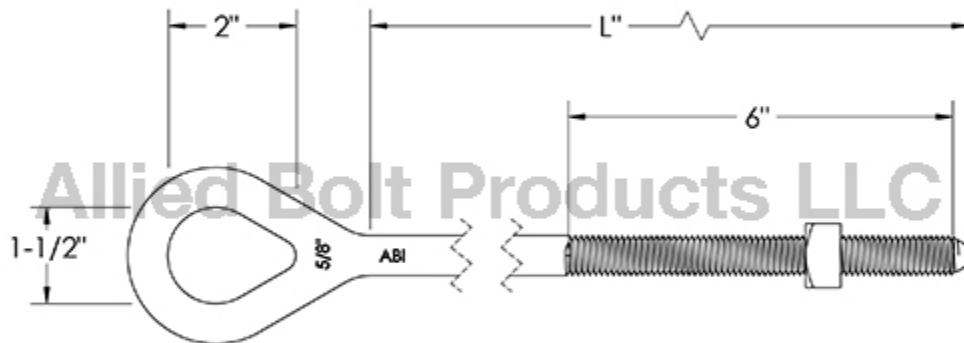

January 08, 2025