

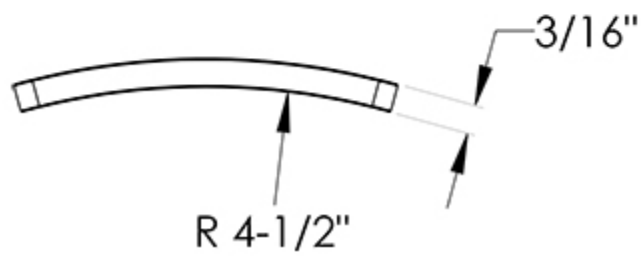

#74555

- Used under the head of bolts and nuts to provide a broader bearing surface and to increase the compression of a tightened nut.
- Washers are thermally Diffused Galvanized per ASTM Specification A1059 and then treated with a silicate based top-coat.
- Bolt and nut are thermal diffused galvanized using Greenkote's™ process to withstand 3,000 hours of Salt Spray per ASTM Specification B117.
- Thermally Diffused Galvanized per ASTM Specification A1059 and then treated with a silicate based top-coat.

74555	2-1/2" X 2-1/2" CURVED WASHER - TDG WITH 11/16" HOLE (3/16" THICK)	50	4	62
-------	---	----	---	----

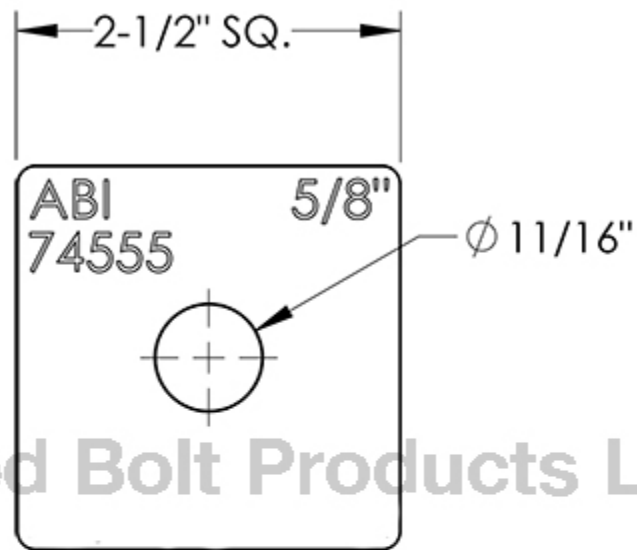

January 09, 2025